

C-104
Banco tipo Bilbao

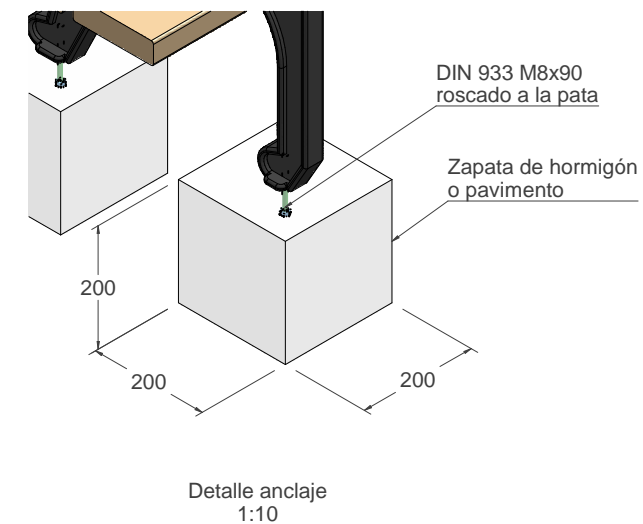
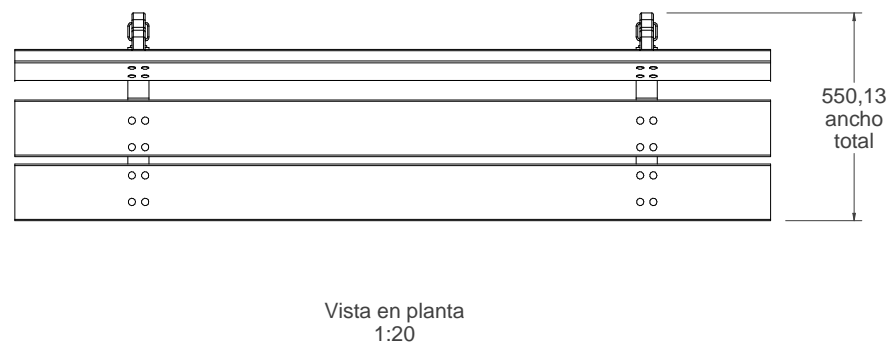
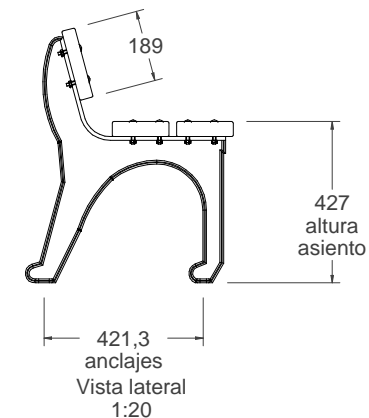
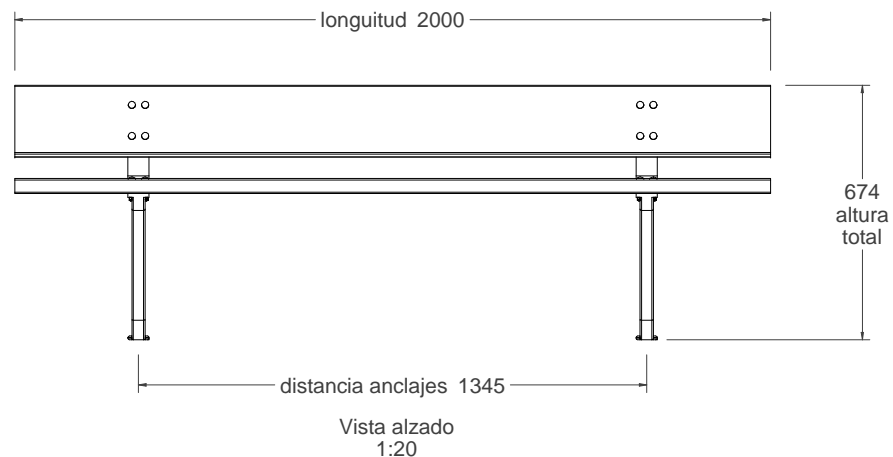
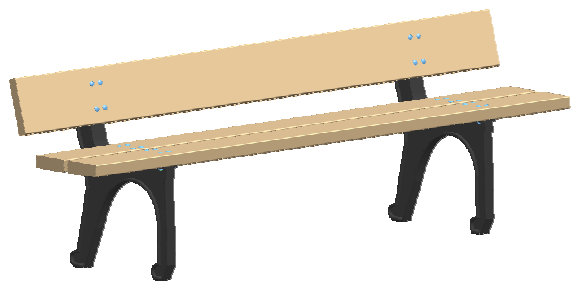

Material:

- Pies: FUNDICION GRIS GG-20
- Madera: MADERA DE GUINEA

Peso: 62,506 kg

Acabados:

- Pies: Pintado oxirón
- Madera: Barniz fungicida e hidrofugo

Anclaje: Tornillo M8x90 (suministrado)